



# COX™ 2-Component Dispenser

## PPM 150

A 2-component manual 300mL dispenser for cartridges.



Model shown: PPM 150 300mL

### Product advantages

- High quality cast aluminum handle
- Epoxy coated steel frame support
- Sintered alloy catch plate
- Warranty up to 2 years\*

### Customer benefits

- For day long comfortable use
- For efficient dispensing
- Wear compensation device (WCD)
- Gives you long worry free performance

### Applications



Bonding



Sealing



Shimming

### Product by range



\*Effective 1st July 2018

The **PPM 150** is part of a range of manual bi-mixer dispensers, designed for use with medium to high viscosity sealants and adhesives.

### Specifications

- Lightweight: 1.52kg / 3.3lbs
- Cartridge Holder Length: 236mm / 14.4inch
- Maximum Thrust: 3.5kN
- Handle Material: Epoxy Coated Aluminum
- Frame Material: Epoxy Coated Steel
- Tool Component Approvals: REACH
- Cartridge Capacity: 300mL (10.5oz)
- Cartridge Ratio: 1:1, 2:1
- Mechanical Advantage Ratio: 18:1
- Viscosity: Medium/High
- Standard Color: Black/Blue
- Customized Versions: Yes

### Dimensions

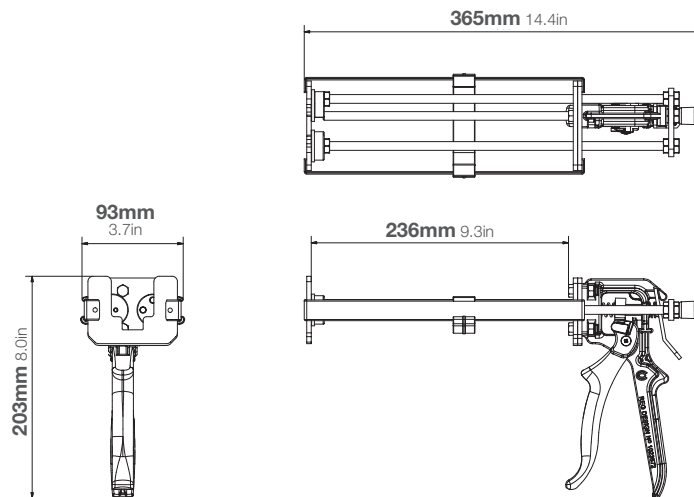

### Part number:

M150 (US)

### Article number:

AP3150

### Packaging:

1 per Box

### Matching MIXPAC™ cartridges

### Compatible side-by-side cartridges

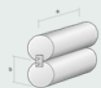

**Plastic Cartridge**  
300mL / 1:1

1:1	mm	inch
a	217.0	8.5
b	Ø28.0	Ø1.1



**Plastic Cartridge**  
225mL / 2:1

2:1	mm	inch
a	217.0	8.5
b	Ø38.0	Ø1.5
c	Ø28.0	Ø1.1

### Conversion kits

### Matching accessories